

**SUNSTREAM**  
BOAT LIFTS

**MODEL NUMBERS**

**24108**

# **COUNTOUR CANOPY**

**ASSEMBLY, INSTALLATION & USE MANUAL**

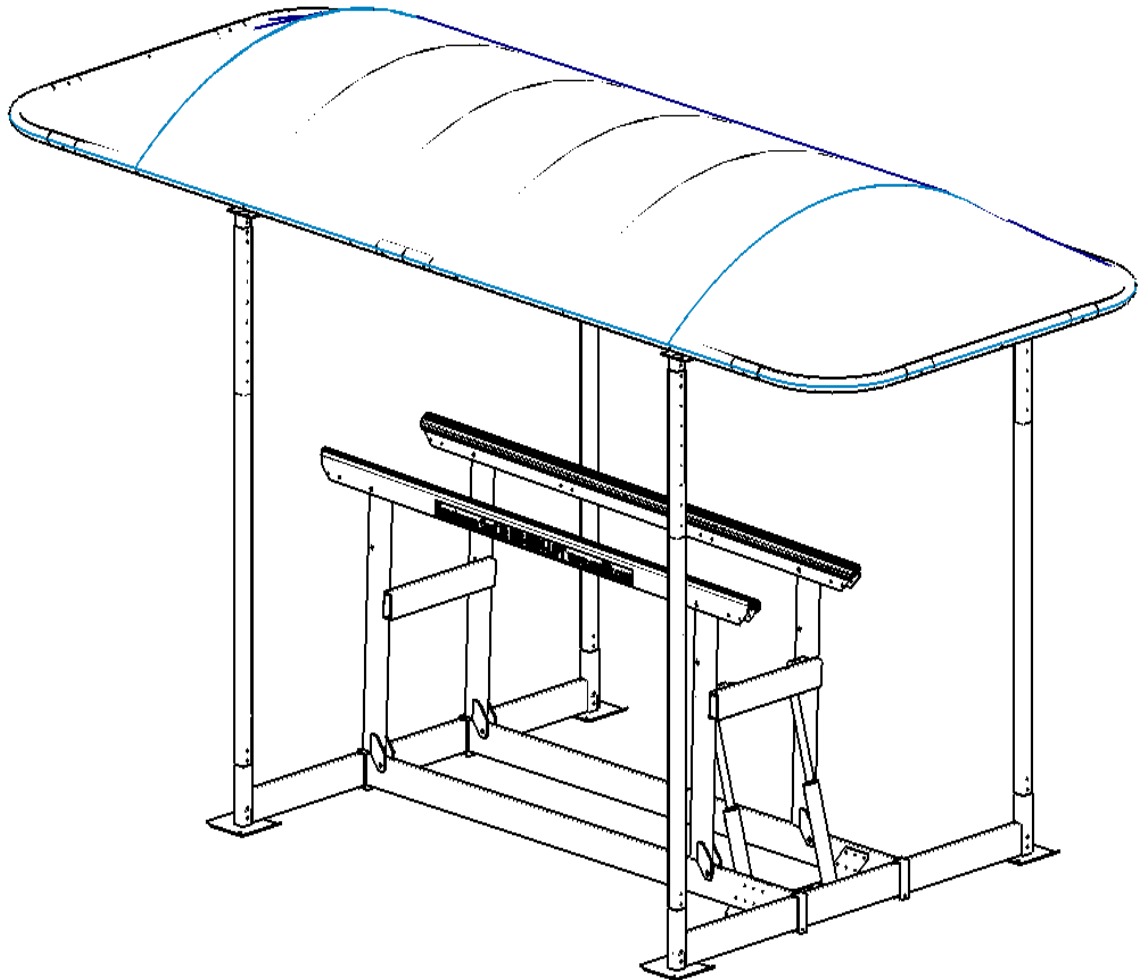

**READ CAREFULLY**

**KEEP THESE INSTRUCTIONS**

COPYRIGHT SUNSTREAM CORPORATION 2011—ALL RIGHTS RESERVED

## **Table of Contents**

Safety/Disclaimer of Liability	3
Parts List	4-5
Assembly	6
Installations	7-11
Warranty	12

## **Tools Recommended**

Socket Wrench with 9/16" and 1/2" Socket

Wrench 9/16"

Wrench 1/2"

Drill

5/16" and 3/8" Drill Bits

3/8" Nut Driver

Screwdriver

## **Safety**



If you have any questions, please call your dealer, or Sunstream at (888)786-5438

Your safety and the safety of others is very important. Proper use of the information in this manual will help avoid potential hazards that could cause damage to property and/or personal injury. It is not possible, however, to identify and warn users of all hazards associated with the assembly, installation, operation, and maintenance. You must use your own good judgment.

Failure to comply with the following rules may result in severe injury and/or death and damage to property.

Only skilled individuals with proper tools should assemble the Hovercover. Improper assembly may lead to product failure and property damage and/or personal injury.

Refer to your SunLift™ owner's manual to review safety specifications for your SunLift.

Be sure the Canopy's height range is properly adjusted for your watercraft to avoid damage to boat windshields or other high reaching fixtures.

Be aware of environmental forces while using the Canopy. Strong winds may cause the cover to become unstable. Remove the fabric cover in the case of predicted extreme weather. The Hovercover is a lightweight structure that is NOT designed to hold body weight. DO NOT hang from the Hovercover.

## **Disclaimer of Liability**

These assembly and installation instructions have been provided by Sunstream Corporation at the request of the potential installer and/or assembler. If you are not an authorized Sunstream Dealer and are not a reasonably skilled mechanic, please contact Sunstream so that we can refer you to a local dealer who can skillfully and safely perform the assembly and installation of your Sunstream boat lift components.

It is the potential installer and/or assembler's responsibility to determine whether he or she has the necessary skills, knowledge, and tools to properly and safely assemble and/or install the Sunstream components described herein. Improper assembly and/or installation may additionally cause a risk to personal safety or property. If the assembler and/or installer is confused or has questions or concerns about a particular assembly or installation, he or she should contact Sunstream by telephone at (253)-395-0500, Int'l (001)-(253)-395-0500 before proceeding further. The information contained in these instructions does not constitute a warranty or guarantee of any kind.

An assembler's and/or installer's failure to correctly follow these assembly and installation instructions constitutes a waiver of the assembler and/or installer's rights against Sunstream regarding any subsequent damages to property or personal injury caused by the assembler's and/or installer's improper assembly and/or installation.

## Parts List

**13** SELF THREADING SCREW, #14-10 X 4", OVAL HEAD, SS  
11-041602-40

**23** MACHINE SCREW, 5/16 X 3.5, ROUND HEAD SLOTTED  
11-051401-90

**8** BOLT, .375-16 X 3.50, HEX, SS  
11-061400-17

**2** BOLT, .375-16 X 2.50, HEX, SS HIGHWIND  
11-061001-92

**16**  
NUT, .3125-18, SS  
12-050000-39

**8**  
NUT, 0.3125, NYLOCK, SS  
12-050000-62

**6**  
NUT, .375-16, NYLOCK, SS  
HIGHWIND 12-060000-22

**15**  
NUT, .375-16, SS  
12-060000-21

**2** U-BOLT, .375-16 X 3.00W X 4.75 (4.50), SS  
15-061800-02

**10**  
VELCRO STRAP W/ GROMMET  
69-000001-00

**12**  
VELCRO STRAP, D-RING, HC RAFTER  
690493

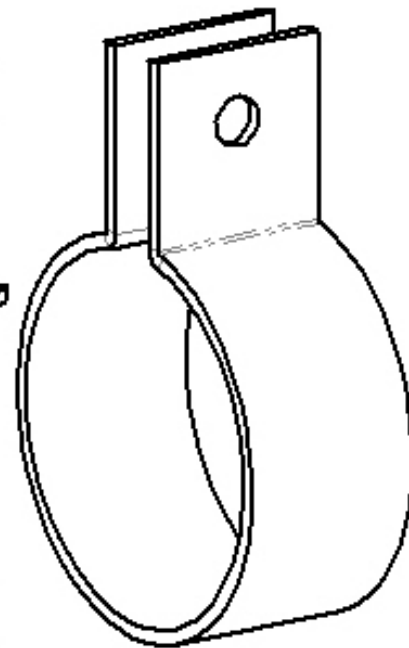

**2**  
Sheet, Clamp, FL10 HoverCover  
42-000012-73

## Parts List

1 X- Sunbrella Top

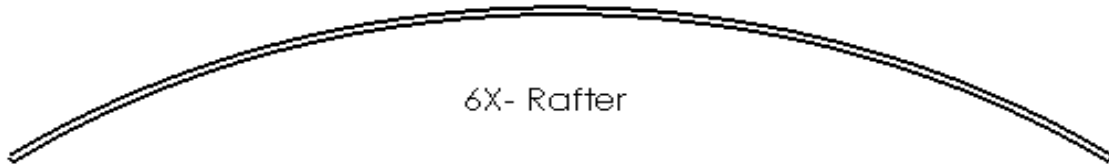

6X- Rafter



4X- Side Tube



2X- End Tube



2X- Union Sleeve



4X- Canopy Upright

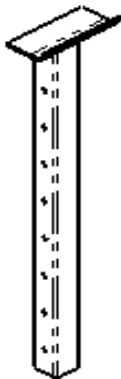

4X- CH24108 Canopy Insert

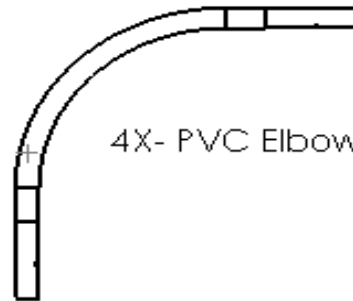

4X- PVC Elbow

## Assembly

Ensure Tubes are oriented correctly. Verify holes 5" from end are connected to the PVC elbows, while the 7" holes are connected to the Union Sleeve. Keep center nuts loose as the High Wind strap will eventually be installed.

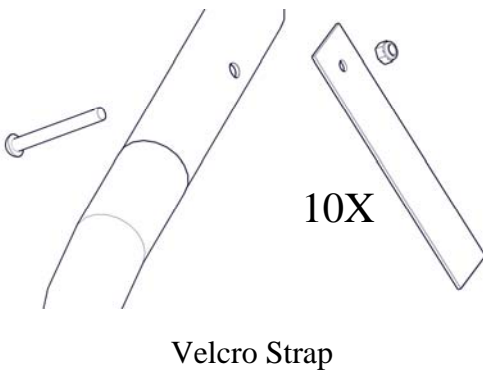
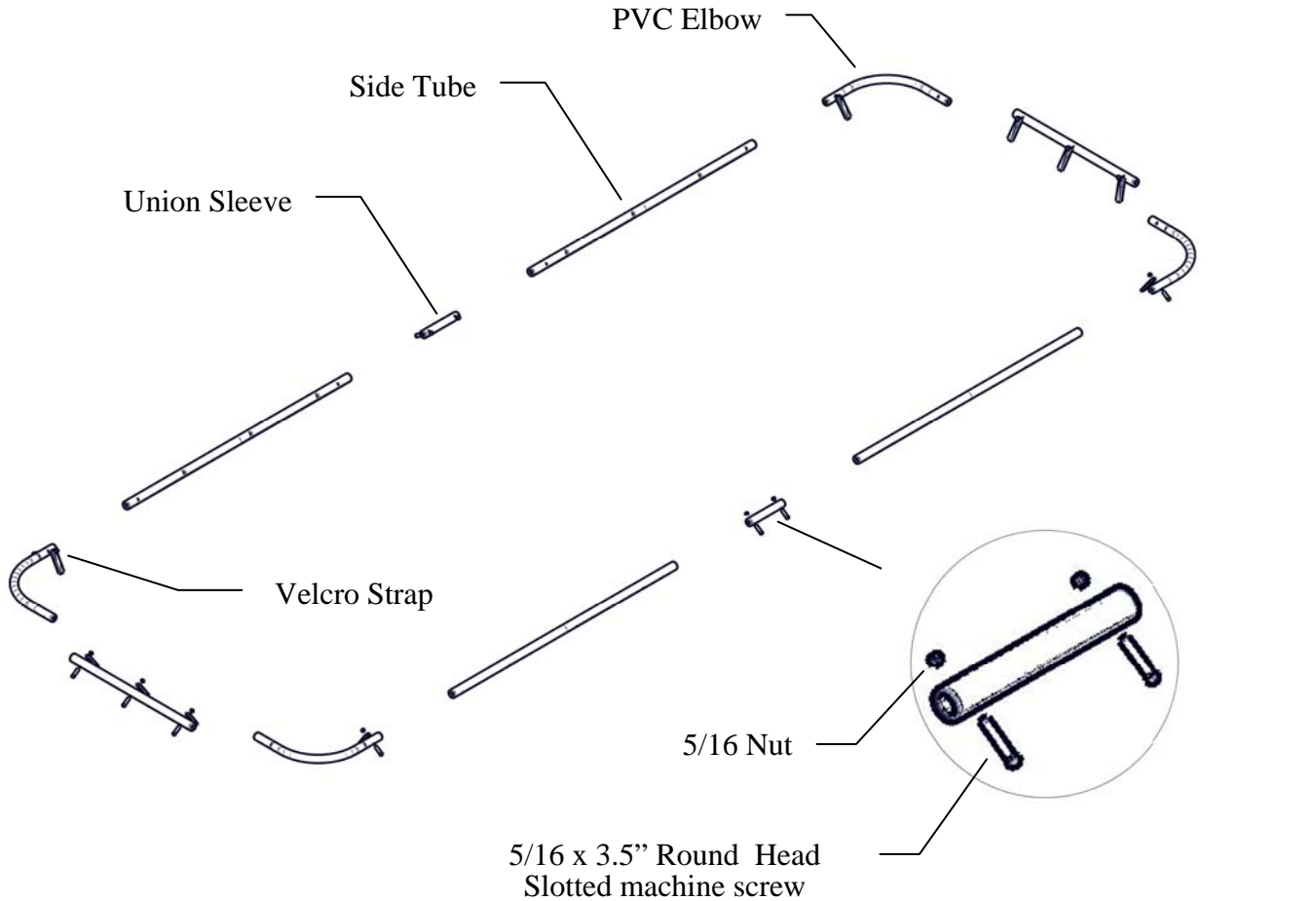

Hooks and loops face towards the inside of the frame.

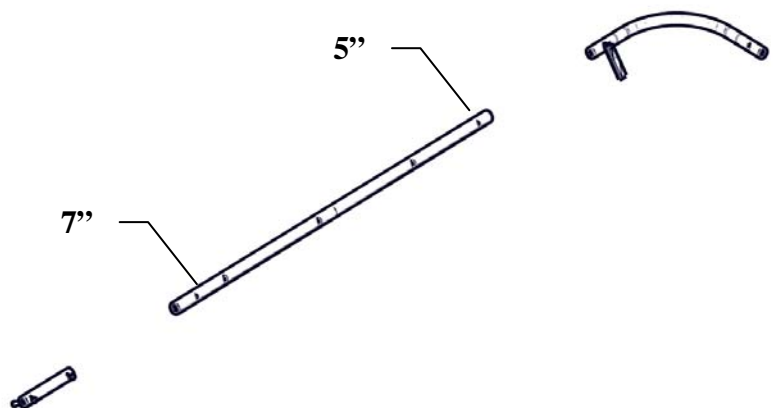

## Assembly

#14 X 4"  
Self Threading  
Screw

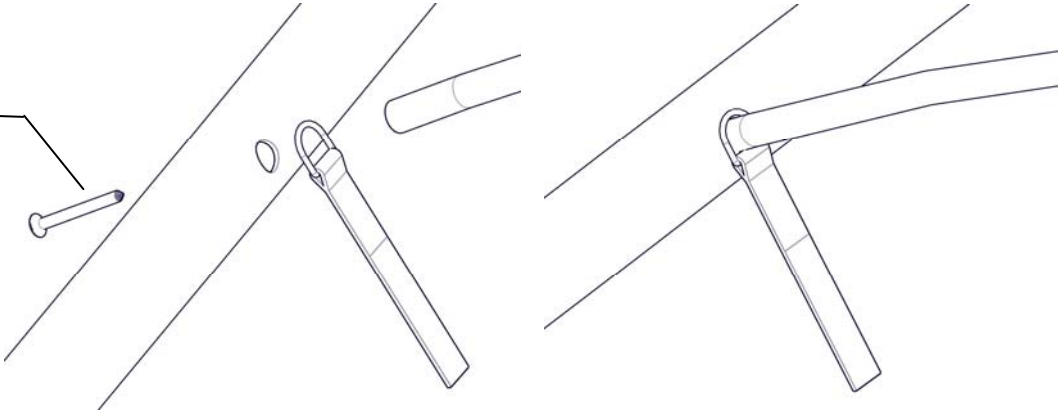

Secure Rafters & D-Ring Velcro Straps. Fasten the rafter and install the High Wind Strap. Sink screws into tubes until head is flush with surface.

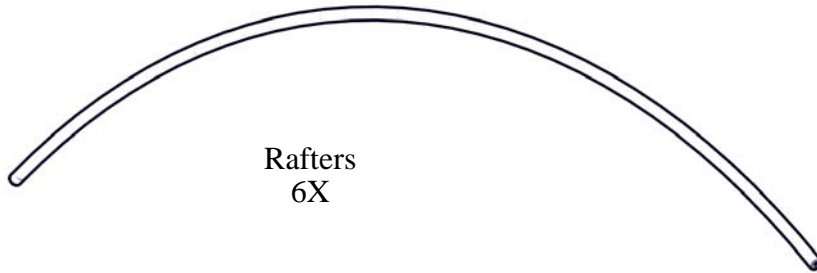

Rafters  
6X

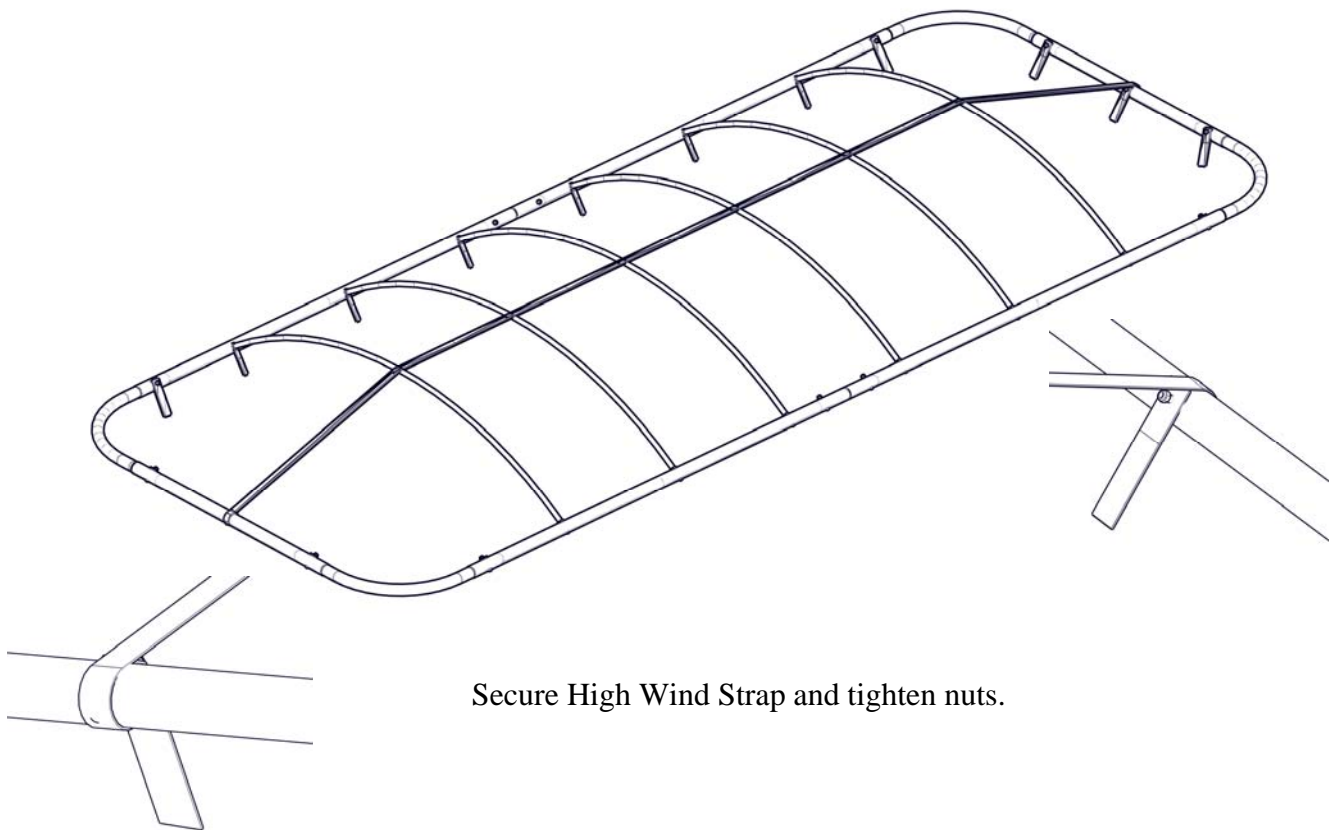

Secure High Wind Strap and tighten nuts.

## Assembly

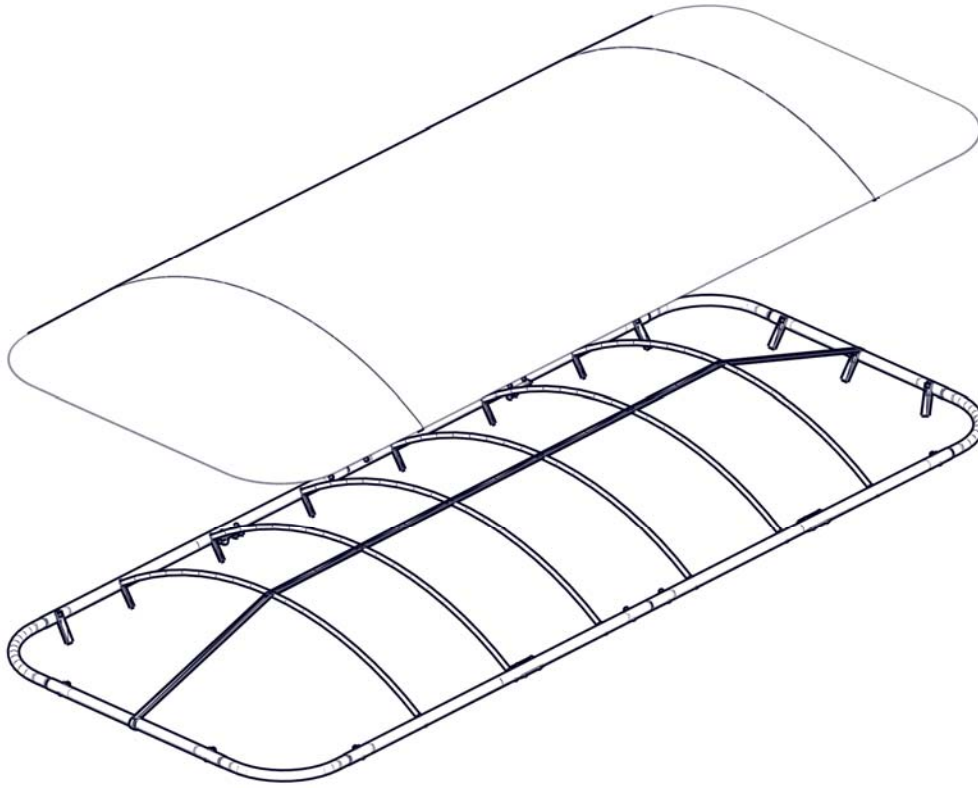

Lay fabric over frame, then pull the three pockets over the corners of the frame while leaving the pull strap pocket for last. Pull 4th corner over with pull strap.

Pull the short side of fabric over frame, and then pull the long side to secure.

Tighten draw string and secure.

Tighten Velcro Straps as needed to remove wrinkles from fabric



# Installation

SL6012 Canopy Insert Orientation

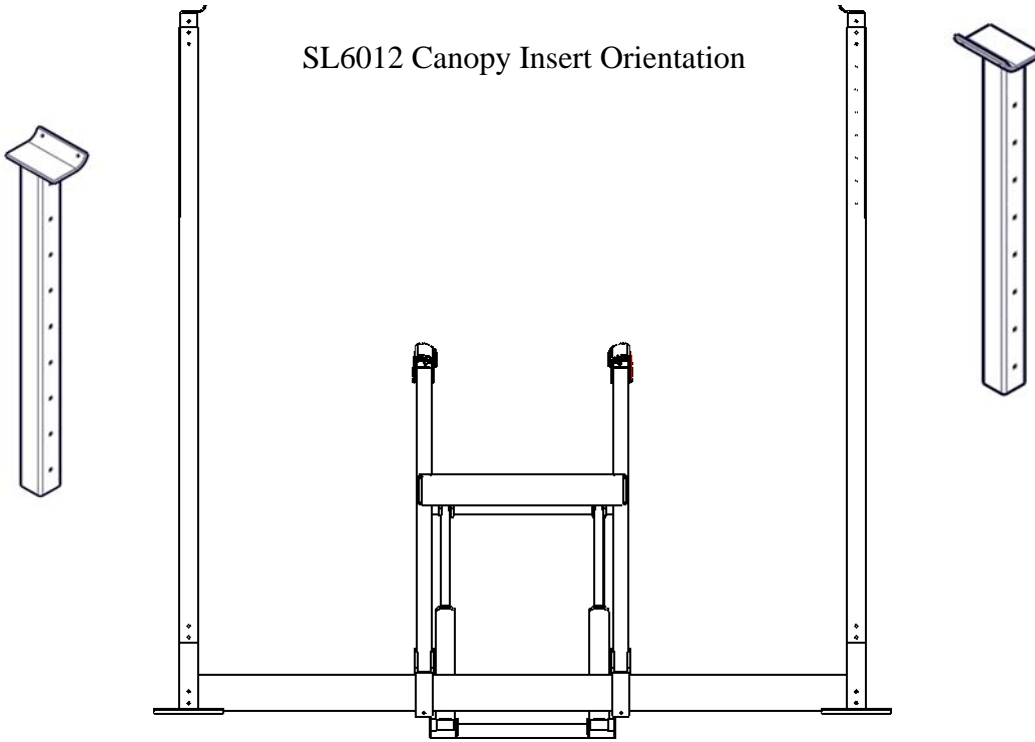

SL3010/4010 Canopy Insert Orientation

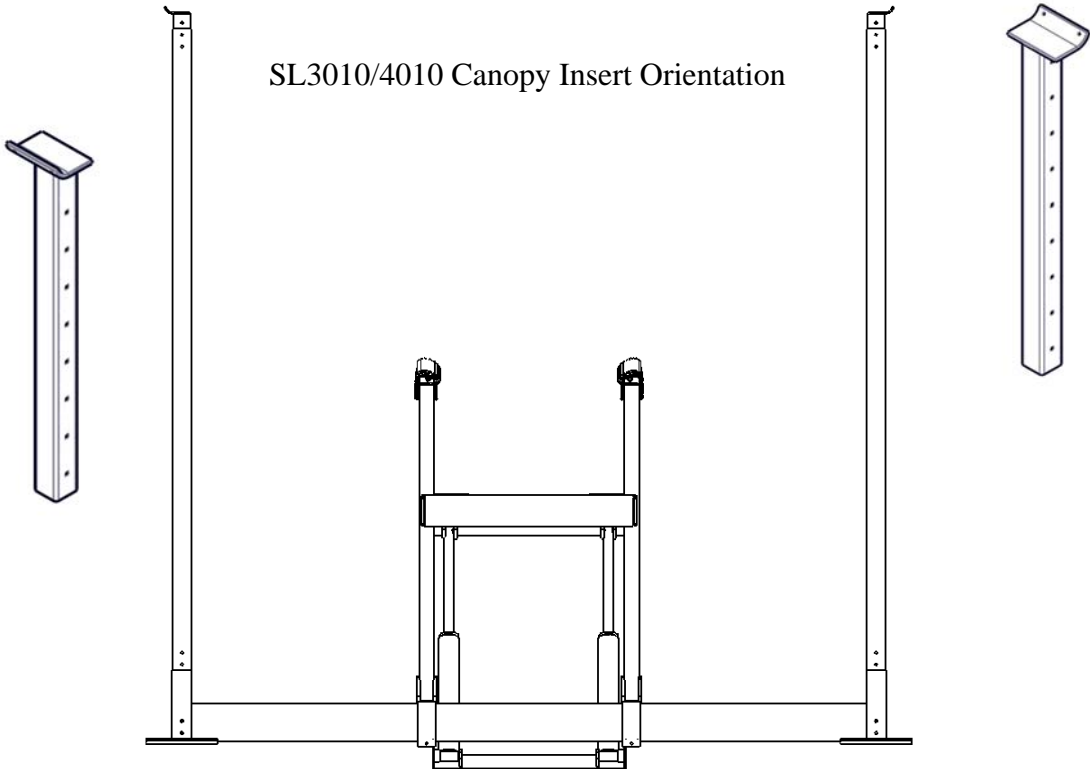

## Installation

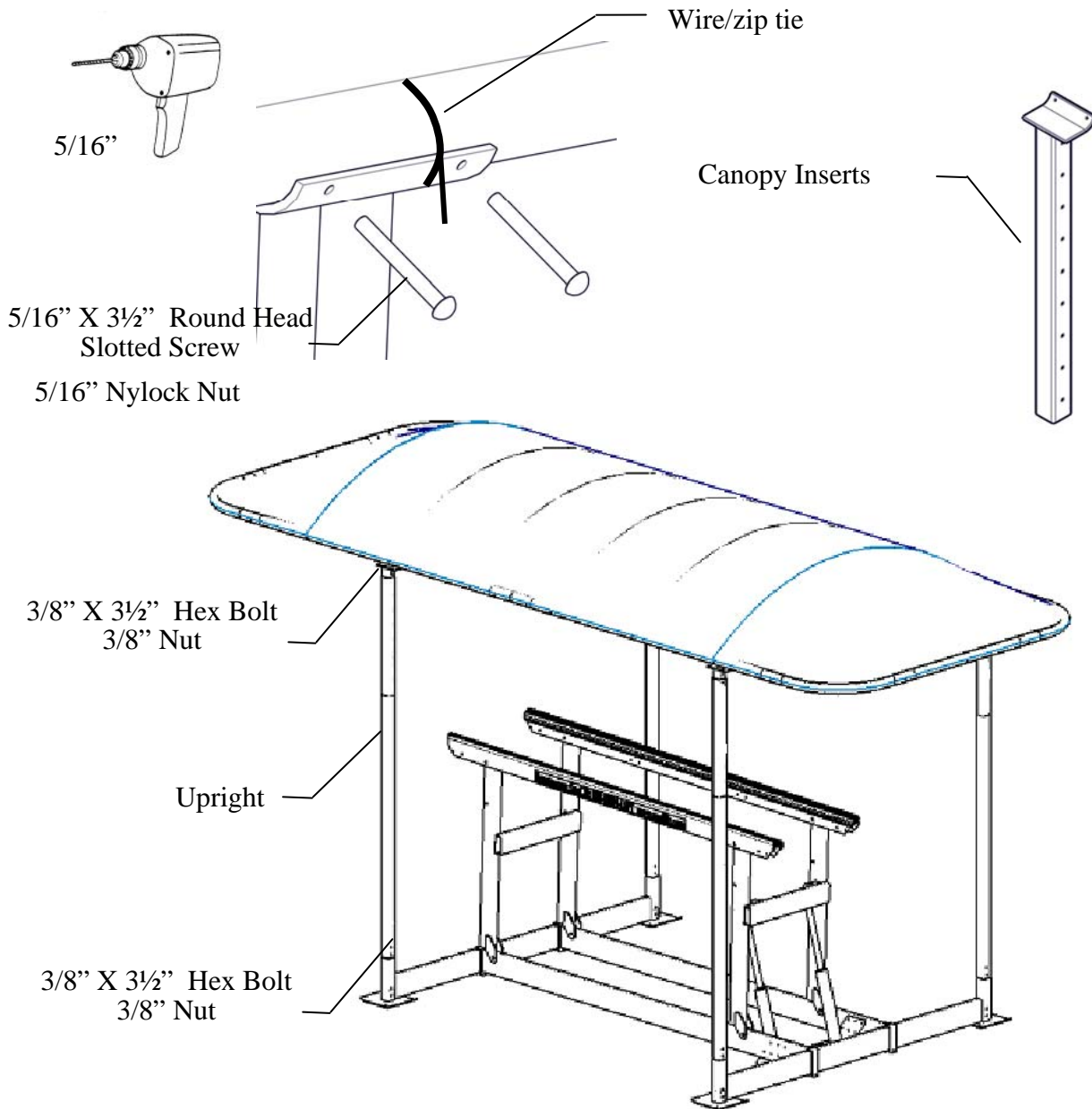

Set Canopy Inserts into the uprights and loosely fasten the fasteners.

Position Canopy to desired location over boat, and tighten Insert fasteners when satisfied. (Use wire/zip ties to temporarily hold canopy while adjusting).

Drill holes through frame using the Canopy Insert as a template.

Fasten Canopy to Inserts, and secure Uprights with noted hardware. (Align hardware to prevent contact with canopy fabric)

## Installation

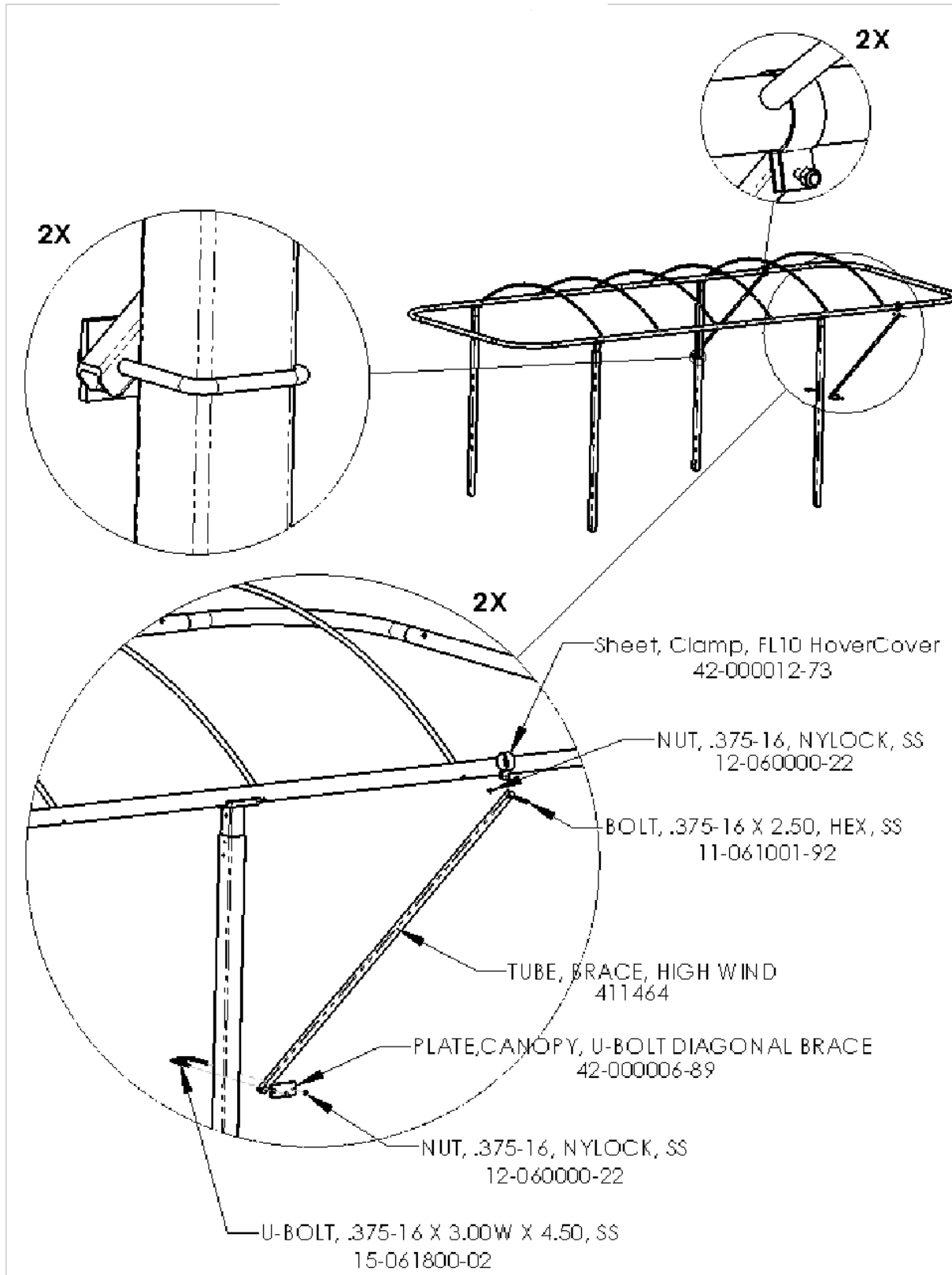

## Standard Warranty

**WARRANTY:** Sunstream Corporation (“Company”) warrants its Products for non-commercial and/or non-governmental use for a period of three (3)\* years, in both fresh and salt water, to the original Purchaser (“Purchaser”) against manufacturing defects in all Product materials and workmanship beginning from date of purchase of the Product from Company\*\* under the following terms and conditions:

**NOTICE REQUIREMENTS AND REMEDIES:** If the Purchaser discovers a defect, the Company, or its authorized Company dealer or agent, will, at the Company’s option: (1) repair the Product, (2) replace the defective part, or (3) refund the purchase price of the Product upon confirmation by Company that the Product is defective, provided that the Company receives notice of the defect from the Purchaser or Company dealer before the warranty period lapses. Product changes caused by age or environment (such as marine growth or heat) shall not constitute a defect. Confirmation of the defect shall require that reasonable proof of the defect be provided by Purchaser to Company or Company dealer, and may include that the Product or part be returned to Company for inspection at Purchaser’s initial expense. This warranty shall not apply if Company receives notification after the before-stated deadline, regardless of when the defect occurred or was discovered, and regardless of the reason for the delay in notification. “Notification” shall be deemed to have occurred when the Purchaser or Company dealer sends written notice to Company by fax or by e-mail and when receipt is confirmed by Company’s response.

**EXCLUSIONS:** This warranty does not apply to damages caused by or due to: (1) accident (including, without limitation, collision, fire, flood, wind, ice or any other natural disaster or acts of God), abuse, misuse, overloading, out of level or improper boat loading (i.e.: not fully on, too far on, or crooked on lift), or (2) faulty assembly or installation if such assembly or installation was not performed by a Company employee or Company dealer. Company is not responsible for determining the weight or dimensions of Purchaser’s boat, and Purchaser is advised that published boat specifications are often inaccurate. This warranty is void if the Product has been modified without the permission of the Company or if any Company serial number has been removed or defaced. Normal maintenance requires an annual inspection of the Product by a Company employee or Company dealer, including bolts, pins, hydraulics, pump, electronics, and welds and failure to undertake such maintenance may constitute “abuse.” Lift components’ fluid level and condition, including battery water and acid, SunFluid and strainer cleaning are maintenance items and are not covered by this warranty. Zincs, ropes, batteries, cosmetic concerns and custom coatings are not covered by this warranty. Batteries supplied by Company that are maintained in top operating condition by Purchaser are warranted for a period of one (1) year. Underwater light systems and the DockJock are not warranted for use in brackish or salt water. This warranty does not void or alter any rights the Purchaser may have against dealers or suppliers of component parts.

**SALT WATER REQUIREMENTS AND EXCLUSIONS:** If any Company Product is used in brackish or salt water, the Purchaser agrees that proper maintenance requires that the Purchaser shall attach to the product, maintain and regularly check sacrificial anodes, also known as “zincs,” in order to prevent electrolysis from damaging the lift metals, and that failure to attach and maintain the zincs constitutes “abuse.” \*\*\* Underwater light systems and the Dock Jock™ personal watercraft lifts are not warranted for brackish or salt water use regardless of zinc use.\*

**INTERNATIONAL WARRANTY:** The Purchaser agrees that if the Product leaves the borders of the United States of America, Puerto Rico or Canada, replacement parts shall be shipped with the dealer’s next container order. International dealers have the option of using parts from stocked product if possible to expedite response. Purchaser has the option to pay for expedited freight if desired.

**LIMITATIONS:** Except as expressly stated herein, there are no warranties, expressed or implied, by operation of law or otherwise, of the Product furnished under this Agreement. Seller disclaims any implied warranty of merchantability or fitness for a particular purpose. The sole remedy for liability of any kind shall be limited to the remedies provided in this warranty and shall in no event include any incidental, indirect, special or consequential damages or loss of use, revenue or profit. State law may override the above exceptions or limitations.

\*Fresh water applications for underwater light systems and the Dock Jock™ winch and strap are warranted for one (1) year; salt water applications are not warranted for these Products.

\*\*If the Product is purchased from a Company dealer, the warranty term begins upon the date the Product is sold to the end Purchaser or three (3) months from the date the Product is shipped from Company, whichever occurs first.

\*\*\*Under normal conditions, zincs should last at least one (1) year. If Purchaser observes that the zincs are deteriorating in a shorter time period, an external current could be entering the system and the Purchaser must find the source of this current and stop it, or change zincs more frequently.

---

### Sunstream Corporation

22149 68<sup>th</sup> Avenue South

Kent, WA 98032

USA

Web Site: [www.sunstreamcorp.com](http://www.sunstreamcorp.com)

Phone: 1-253-395-0500

001-253-395-0500 (Int'l)

E-mail: [warranty@sunstreamcorp.com](mailto:warranty@sunstreamcorp.com)

Fax: 1-253-395-0501

001-253-395-0501 (Int'l)